

Shaded Pole AC Motor



Lamination Dimension 60x64

Technical Data	
Voltage Range	100-240VAC
Insulation Class	A/E/B/F/H
Rotating Direction	CCW/CW
Working Standard	Continues
Lamination Dimension	60x64mm

Typical Application
Microwave Overns
Ceilling-inserting AC
Bath Machines
Air Purifier
Heaters



Specification

Model	Voltage (A)	Frequency (Hz)	Free Load			On Load				Max. Toruqe (mN.m)	Start Torque (mN.m)	Output Power (W)
			Current	Power	Speed	Current	Power	Speed	Torque			
			(A)	(W)	(Rpm)	(A)	(W)	(Rpm)	(mN.m)			
AC6010-35	220	50	0.13	12	2820	0.15	15	2300	5.88			1.4
AC6013-35	220	50	0.15	15	2830	0.17	17.5	2300	8.82			2.2
AC6014-35	220	50	0.17	18	2850	0.19	20	2350	12.74			3.2
AC6016-35	220	50	0.18	21	2850	0.2	23	2350	14.70			3.7
AC6020-35	220	50	0.2	22	2850	0.21	25	2500	16.56			4.5
AC6026-35	220	50	0.23	25	2850	0.25	28	2550	19.60			5.4
AC6030-35	220	50	0.27	28.5	2850	0.29	31	2600	23.00			6.45
AC6035-35	220	50	0.3	31.5	2850	0.32	34.5	2600	26.46			7.42
AC6040-35	220	50	0.34	38	2850	0.38	41	2600	29.50			8
AC6010-16	120	60	0.15	12	2820	0.17	17.5	2300	5.58			1.6
AC6013-16	120	60	0.17	15	2830	0.19	20	2300	8.82			2.4
AC6014-16	120	60	0.18	18	2850	0.2	23	2350	12.74			3.5
AC6016-16	120	60	0.2	21	2850	0.21	25	2350	14.70			3.9
AC6020-16	120	60	0.23	22	2850	0.25	28	2500	16.56			4.8
AC6026-16	120	60	0.27	25	2850	0.29	31	2550	19.60			5.9
AC6030-16	120	60	0.3	28.5	2850	0.32	34.5	2600	23.00			6.8
AC6035-16	120	60	0.34	31.5	2850	0.38	41	2600	26.46			7.9
AC6040-16	120	60	0.38	38	2850	0.41	44	2600	29.50			8.5

Outline Drawing

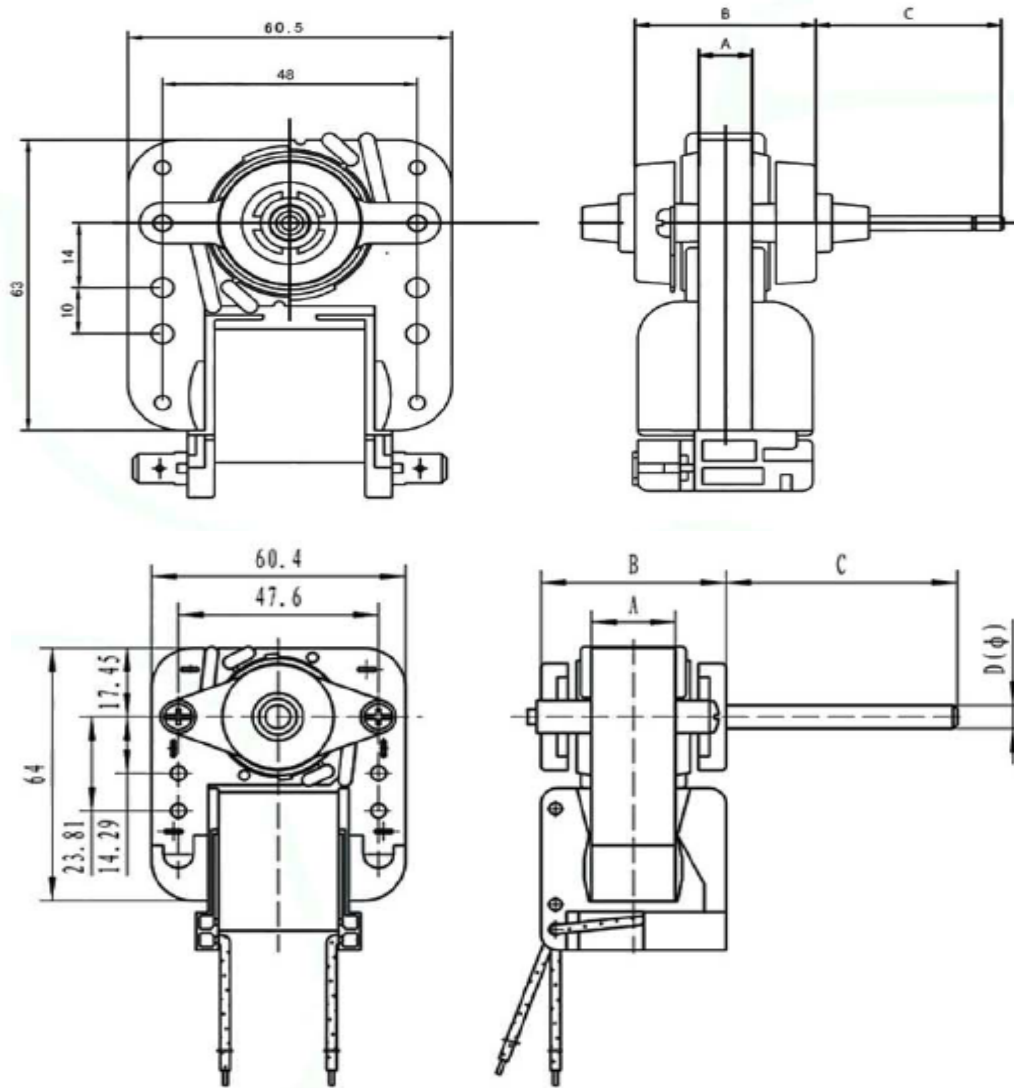

Dimensions

Model	A (mm)	B (mm)	C (mm)	D (mm)
AC6010-35	10	39	10mm~200mm	Φ3.17~Φ6.35
AC6013-35	13	42		
AC6014-35	14	44		
AC6016-35	16	45		
AC6020-35	20	49		
AC6026-35	25	54		
AC6030-35	30	59		
AC6035-35	35	64		
AC6040-35	40	69	10mm~200mm	Φ3.17~Φ6.35
AC6010-16	10	39		
AC6013-16	13	42		
AC6014-16	14	44		
AC6016-16	16	45		
AC6020-16	20	49		
AC6026-16	25	54		
AC6030-16	30	59		
AC6035-16	35	64		
AC6040-16	40	69		

