

Universal AC Motor

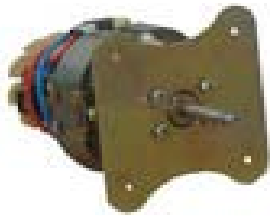

Lamination Dimension $\Phi 70\text{mm}$

AU7018



AU7020



AU7023

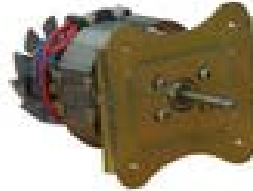

AU7030



Typical Applications: Juicer
Blender

Lamination Dimension: $\Phi 70\text{mm}$
Shaft Diameter: $\Phi 6.35\text{mm}$

Specification

Model	L (mm)	Stake Length (mm)	Nominal Voltage (V)	Frequency (Hz)	No Load			At Maximum Efficiency				Output Power (W)
					Speed	Current	Input	Efficiency	Torque	Speed	Current	
					(rpm)	(A)	(W)	(%)	(mN.m)	(Rpm)	(mN.m)	
AU7018	127.5	18	230	50	15393	0.390	87.77	45.2	68.10	100	0.713	70.97
AU7023	125.4	23	230	50	15482	0.682	159.3	49.1	144.90	10004	1.361	151.8
AU7025	133.5	25	230	50	24041	0.489			113.80	14883	1.283	177.4
AU7030	147	30	230	50	19489	0.650			163.60	12816	1.493	322.2

Outline Drawing - Representative Model

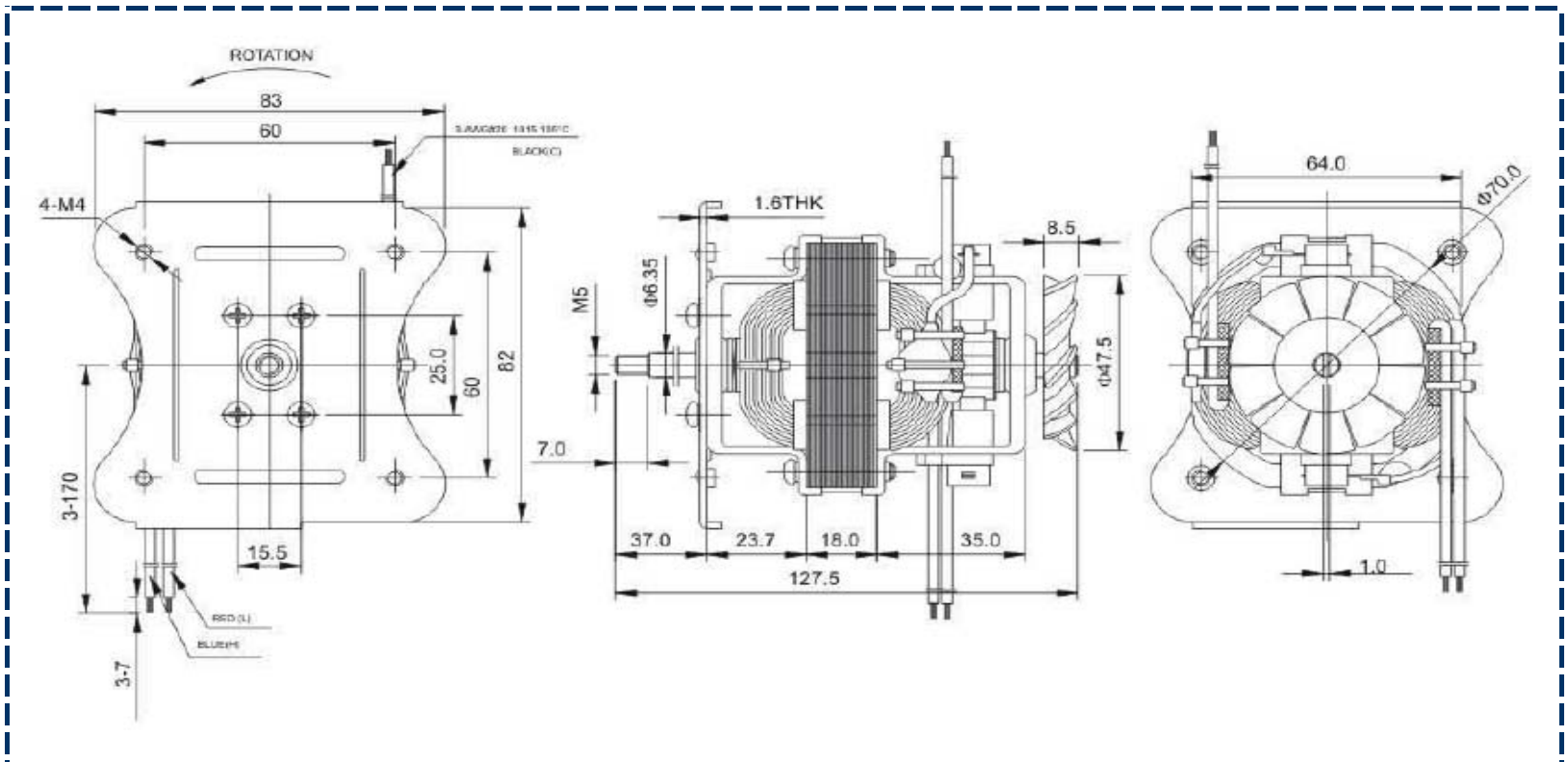

Outline Drawing - Representative Modle

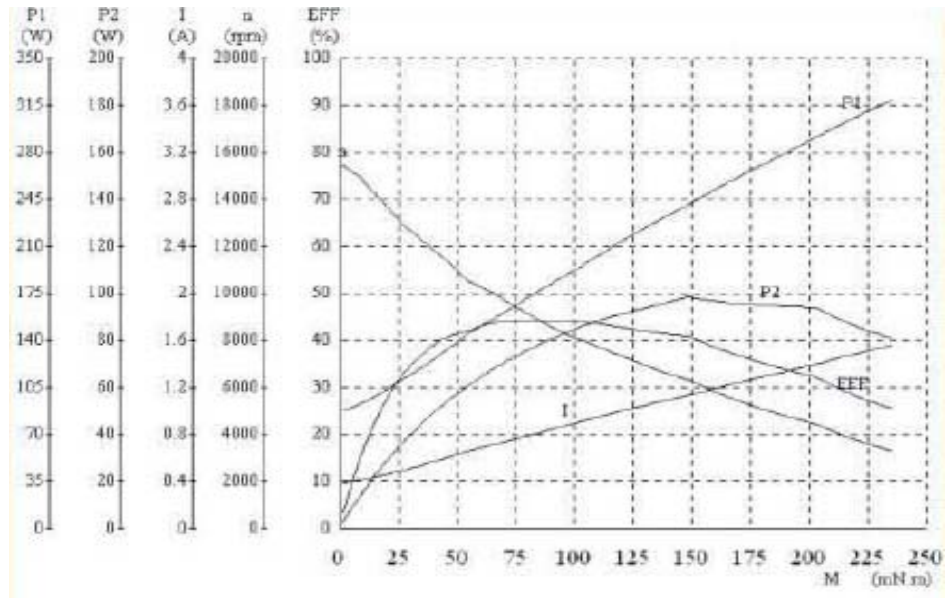

9812 Whithorn Dr., Houston, TX 77095, Phone: 281.855.2218, Fax: 281.859.8825, Email: motors@telcointercon.com