

Stepper Gear Box

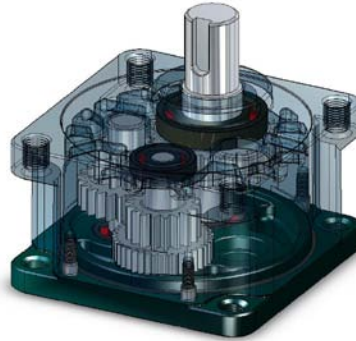

EP42



Gear Ratio	1:3.6	1:7.2	1:10	1:20	1:30	1:50
Permissible Torque N.m(kgcm)	0.35 (3.5)	0.7(7)	1.0(10)	1.5 (15)		
Permissible Thrust Force N (kg)	15(1.5)					
Permissible Loading Weight N(kg)	20 (2.0)					
Backlash	35(0.58°)	25 (0.42°)	20 (0.33°)			
Output Shaft Speed (r/min)	0~500	0~250	0~180	0~90	0~60	
A Dimension (mm)	31					

DRAWING

