

PM Stepper Motor



2P-10180-015

General specification

Step angle accuracy	+/- 10% (full step, no load)
Resistance accuracy	+/-10%
Inductance accuracy	+/- 20%
Temperature rise	80°C Max. (Rated current, 2 phase on)
Ambient temperature	20°C ~+ 50°C
Insulation resistance	100MΩ Min, 500VDC
Dielectric strength	500VAC / minute
Shaft Radial play	0.06 Max. (450g-load)
Shaft Axial play	0.08 Max. (450g-load)
Insulation Class	E for Coils

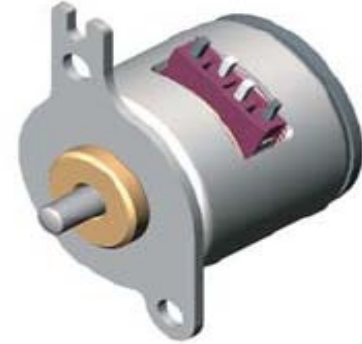

Specification

Model	Voltage	Phase	Current	Step angle	Resistance at 25C	Holding torque	Pull in Torque	Pull out Torque
	(v)		(A)	(degree)	(Ω)	(min. gf.cm)	(min. gf.cm)	(min. gf.cm)
2P10180-015	2.4	2	0.15/ Phase	18	18			

Outline Drawing

Dimension (Units:mm)

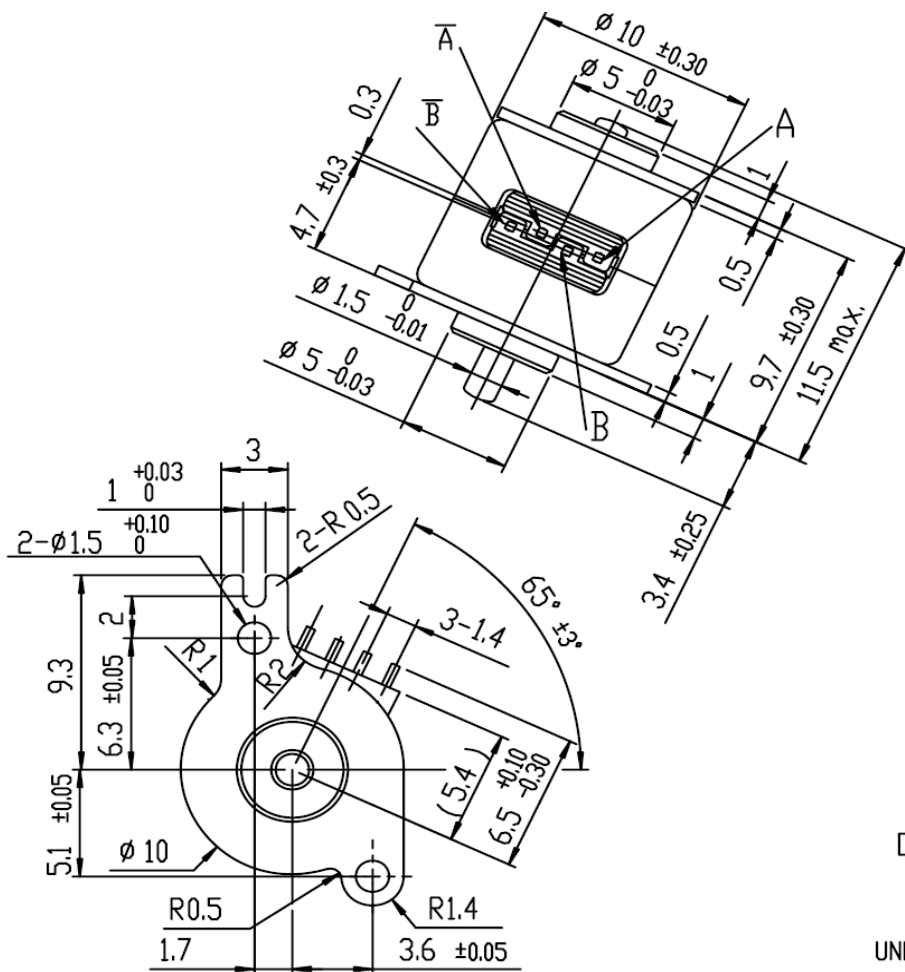

CONNECTION DIAGRAM



SEQUENCE OF EXCITATION

STEP PHASE	1	2	3	4
A	H	H	L	L
Ā	L	L	H	H
B	L	H	H	L
B̄	H	L	L	H

OUTPUT SHAFT ROTATION CW

UNLESS OTHERWISE SPECIFIED ± 0.1

Performance Curve

