

PM Stepper Motor



2P10180-018

General specification

Step angle accuracy	+/- 10% (full step, no load)
Resistance accuracy	+/-10%
Inductance accuracy	+/- 20%
Temperature rise	80°C Max. (Rated current, 2 phase on)
Ambient temperature	20°C ~+ 50°C
Insulation resistance	100MΩ Min, 500VDC
Dielectric strength	500VAC / minute
Shaft Radial play	0.06 Max. (450g-load)
Shaft Axial play	0.08 Max. (450g-load)
Insulation Class	E for Coils



Specification

Model	Voltage	Phase	Current	Step angle	Resistance at 25C	Holding torque	Pull in Torque	Pull out Torque
	(v)		(A)	(degree)	(Ω)	(min. gf.cm)	(min. gf.cm)	(min. gf.cm)
2P10180-018	3.3	2	0.18/ Phase	18	20			

Outline Drawing

Dimension (Units:mm)

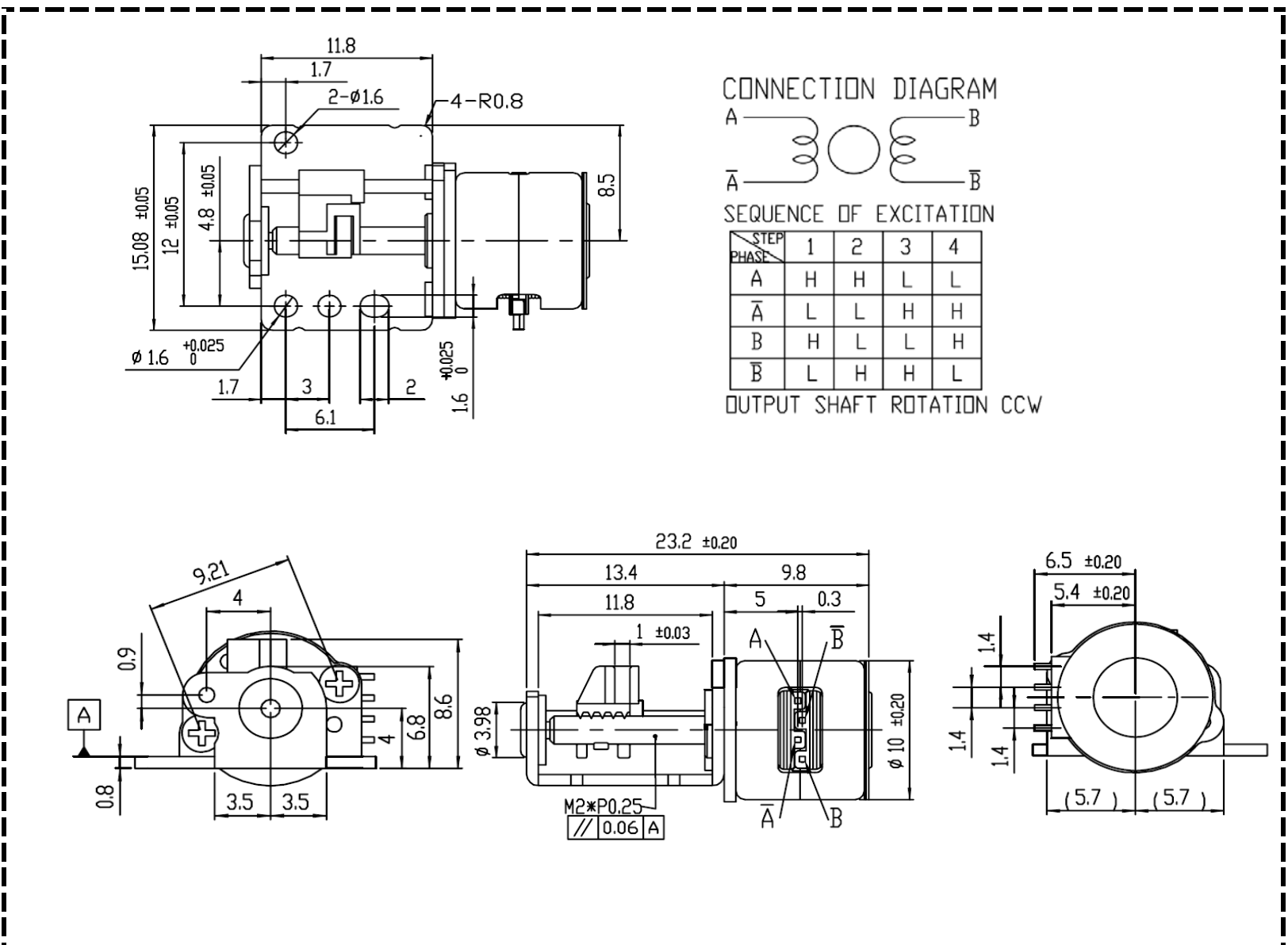

Performance Curve

