

# Stepper Motor with Integrated Driver



## 4T56 Series

### General Specification

Model No.	4T5618-6I
Power Input	DC18~30V
Rated Current	Max 2A
Step Resolution	200, 400, 800, 1600 (-A) or 3200 (-B)
Auto Current Down	0.52%
Control Mode	1 Pulse
Max. Pulse Rate	150K Hz
PWM	2us (Min)
Direction Response Time	20us (Min)
Input Signal	+4 ~ +10V <20mA
Input Signal Resistance	220Ω
Output Signal	Open loop, 24V, 10mA (Max)
Noise Insulation	Photo Coupler
Connection	movable slot
Operating Temperature	0°C+40°C

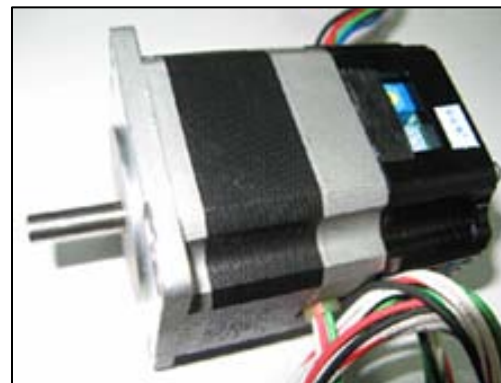

### Outline Drawing

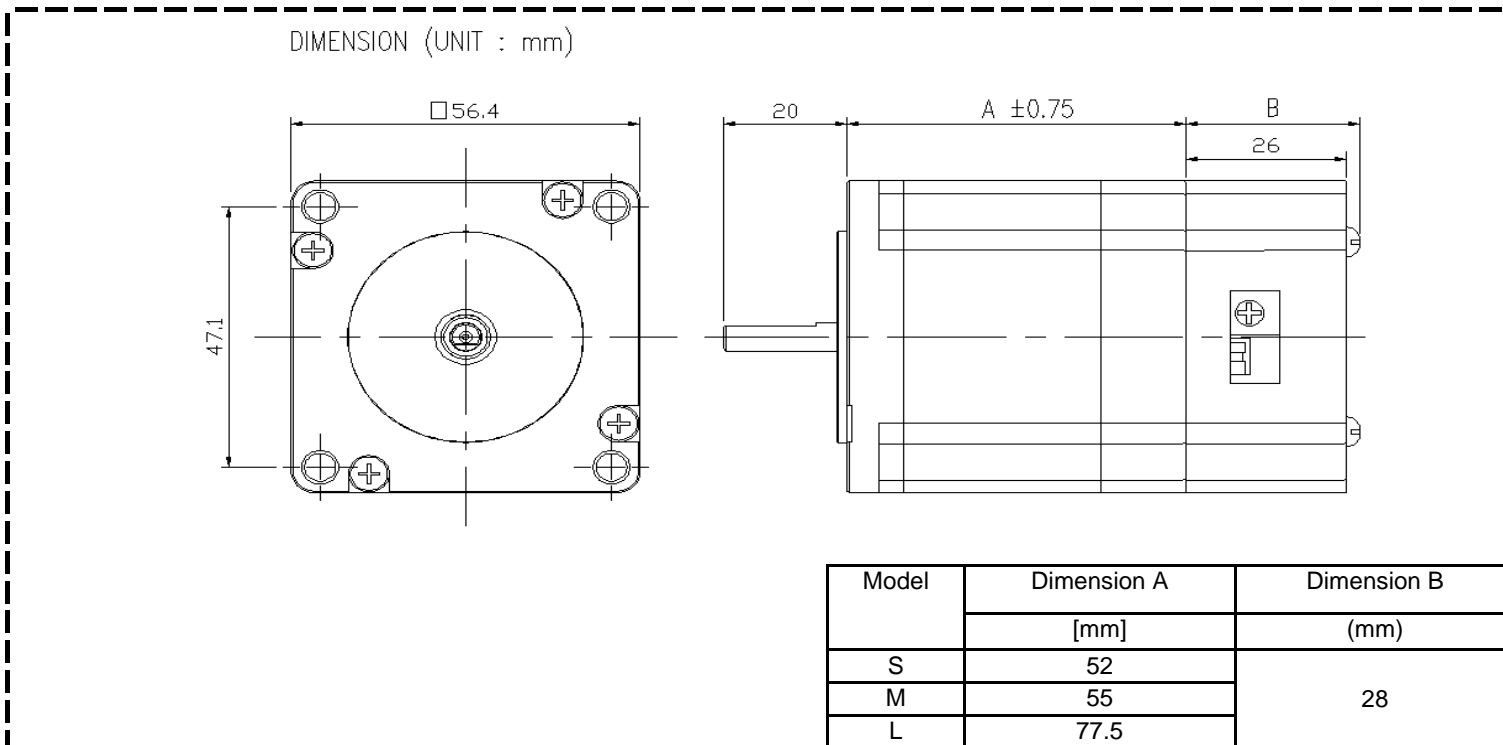

### Motor Speed Torque Performance Curve

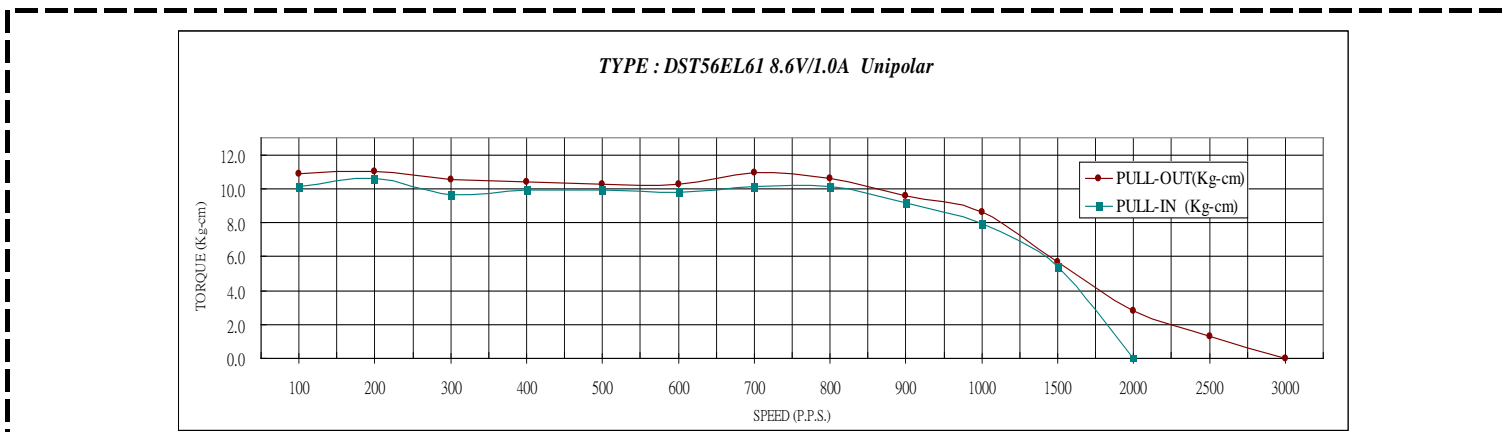

**Control Diagram**

